



Technical Data

VSD Intelligent Pump - GAI 750

Revision no.

Page:
1

Receiver

From

Company name
Respons. Department
Person in charge
Phone number
Fax no
E-mail address



Brand: Gol Pumps
Model: GAI 750

Features:

- Permanent Magnet Variable Frequency Drive
- Low-Noise Supercharger
- Energy-Saving and Environmentally Friendly
- Multiple Protection

Dimensions:

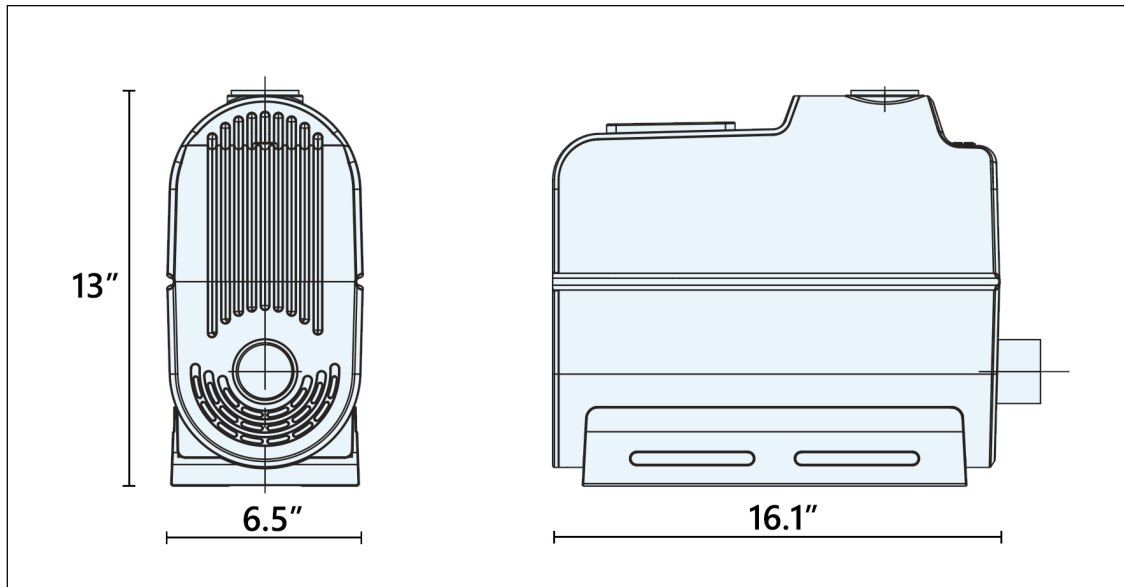

Dimensions (inch)	
Inlet	Outlet
1	1

Project

Project ID

Created by

Created on

Last update



Performance Curves

VSD Intelligent Pump - GAI 750

Revision no.

Page:
2

Receiver

From

Company name
 Respons. Department
 Person in charge
 Phone number
 Fax no
 E-mail address

Model	Voltage - Phase	Power		Water Temp Range	Ambient Temp Range	Pressure Adjustment Range	Max. Flow	Max. Lift	Rated Flow	Rated Lift	Suction
	V	W	Hp	°F	°F	PSI	GPM	ft	GPM	ft	ft
GAI 750	220 - 1Ph	750	1	32-212	32-122	21.8-79.8	24.7	180.4	13.2	91.9	19.7

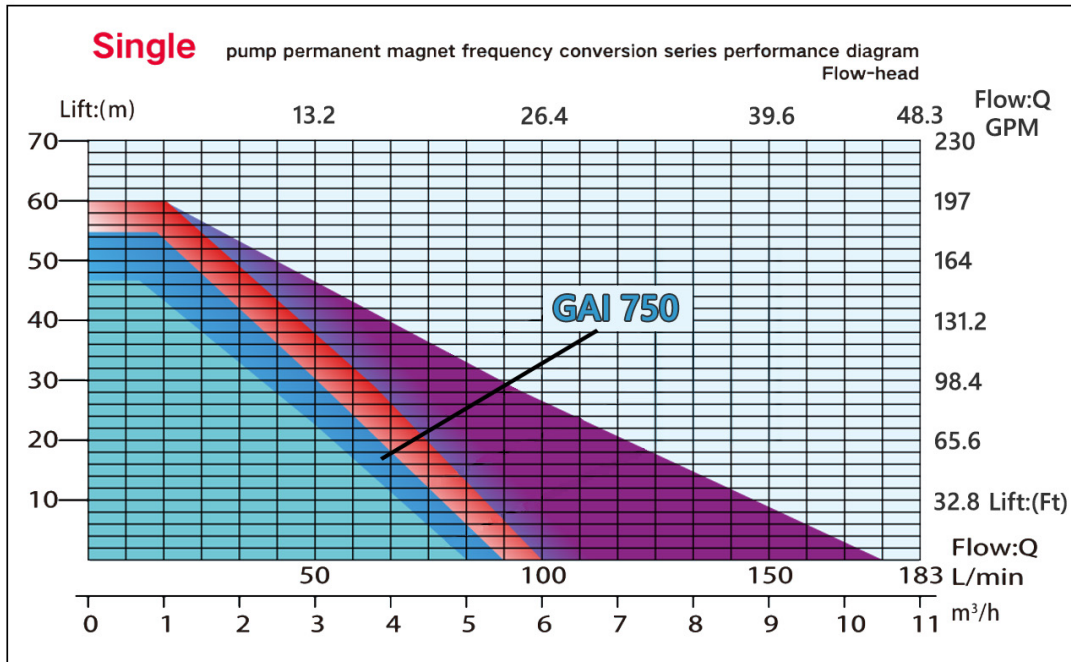

Project	Project ID	Created by	Created on	Last update
---------	------------	------------	------------	-------------