



Technical Data

Vertical In-line Pump - EGM80-6516-02204

Revision no.

 Page:
1

Receiver

From

 Company name
 Respons. Department
 Person in charge
 Phone number
 Fax no
 E-mail address

Brand: Gol Pumps
Model: EGM80-6516-02204
Flange: ANSI Class 125

Motor (V1)

Model	HP
Y2-100L1-4	3

Weight (lb)

Pump	Motor	Pump & Motor
121	74.8	193.6

Inlet Outlet

3"	3"
----	----

Dimensions:

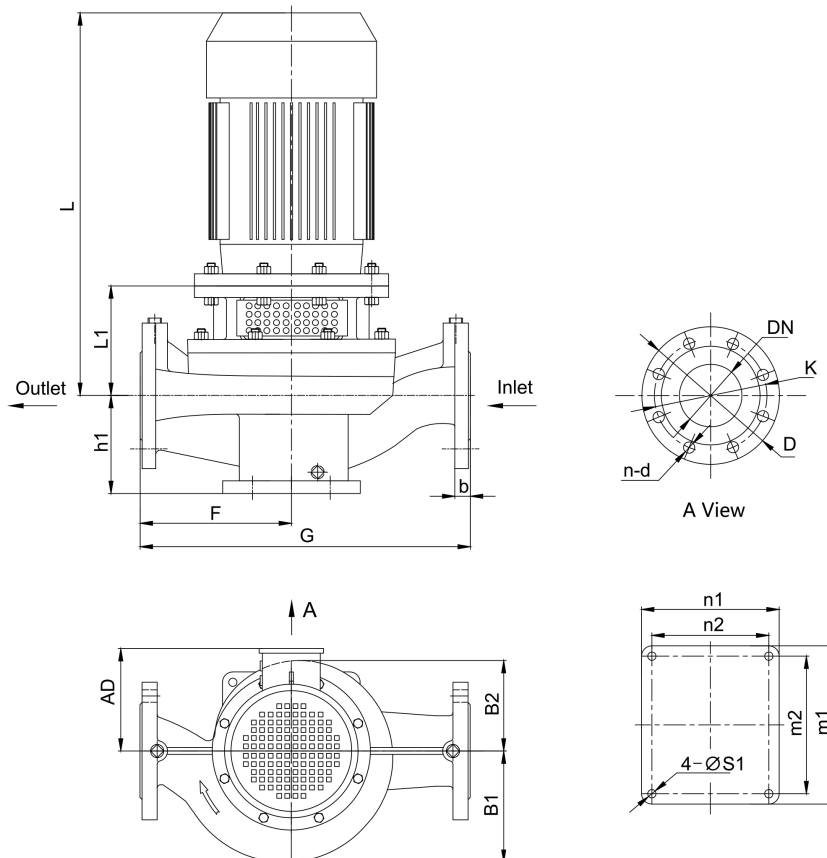

Pump Installation Size (inch)

h1	L1	F	G	L	AD	B1	B2	n2 x m2	n1 x m1	S1	DN	D	K	n - d	b
6.2	6.5	8.7	18.9	19.3	7.1	6.4	5.2	6.7x7.9	7.9x9.1	0.5	3	7.5	6	4 - ϕ 0.8	-

Project

Project ID

Created by

Created on

Last update



Performance Curves

Vertical In-line Pump - EGM80-6516-02204

Revision no.

 Page:
2

Receiver

From

 Company name
 Respons. Department
 Person in charge
 Phone number
 Fax no
 E-mail address

Model	Capacity			Head		Speed	Motor	Voltage	Phase	Impeller Diam.		Eff.	(NPSH)r
	m ³ /h	l/s	gpm	m	ft	r/min	hp	v		mm	inch	%	ft
EGM80-6516-02204	36.7	10.2	161.7	11	36	1710	3	230/460	3	160	6.3	71	8.5
	62.1	17	269.5	9	30		3					79	10.5
	73.4	20.4	323.3	7.2	24		3					71	11.8

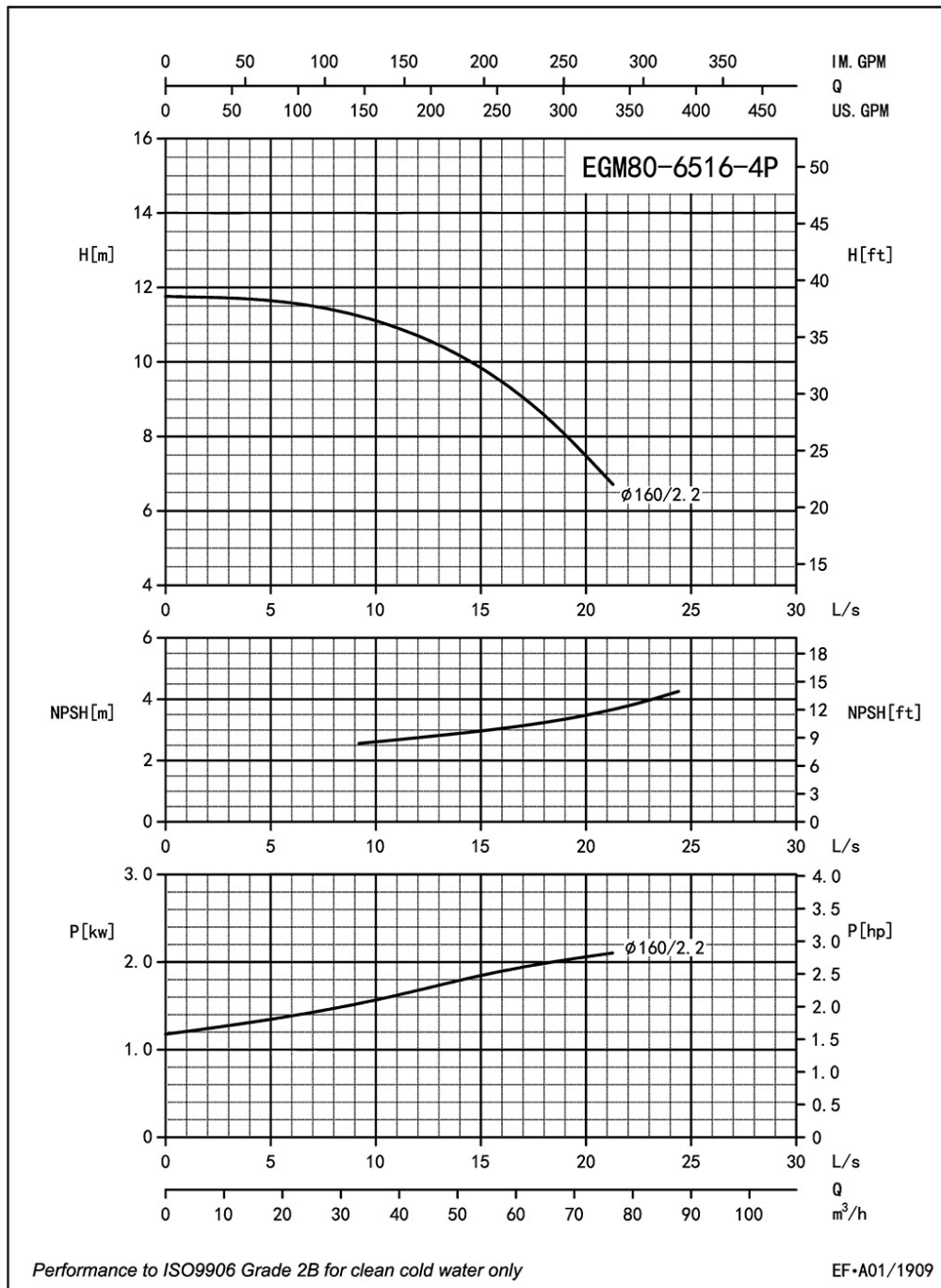

Project

Project ID

Created by

Created on

Last update



Parts List

Vertical In-line Pump - EGM80-6516-02204

Revision no.

Page:
 3

	Receiver	From
Company name		
Respons. Department		
Person in charge		
Phone number		
Fax no		
E-mail address		

Parts List

1 Cassing	14 Screw
2 Impeller Nut	15 Screw Bolt
3 Flat Washer	16 Screw Nut
4 Spring Washer	17 Screw Bolt
5 Front-Wear Ring	18 1/4 Plug
6 Impeller	19 3/8 Plug
7 Seal Seat	20 Key
8 Mech Seal	21 Screw Nut
9 Casing Gasket	22 Motor
10 Casing Cover	23 Key
11 1/4 Plug	24 Screw
12 Adapter	25 Shaft
13 Guard	

Project	Project ID	Created by	Created on	Last update