



Technical Data

Vertical In-line Pump - EGM100-8020-07504

Revision no.

Page:
 1

	Receiver	From
Company name		
Respons. Department		
Person in charge		
Phone number		
Fax no		
E-mail address		



Brand: Gol Pumps
Model: EGM100-8020-07504
Flange: ANSI Class 125

Motor (V1)	
Model	HP
Y2-132M-4	10

Weight (lb)		
Pump	Motor	Pump & Motor
176	173.8	347.6

Inlet	Outlet
4"	4"

Dimensions:

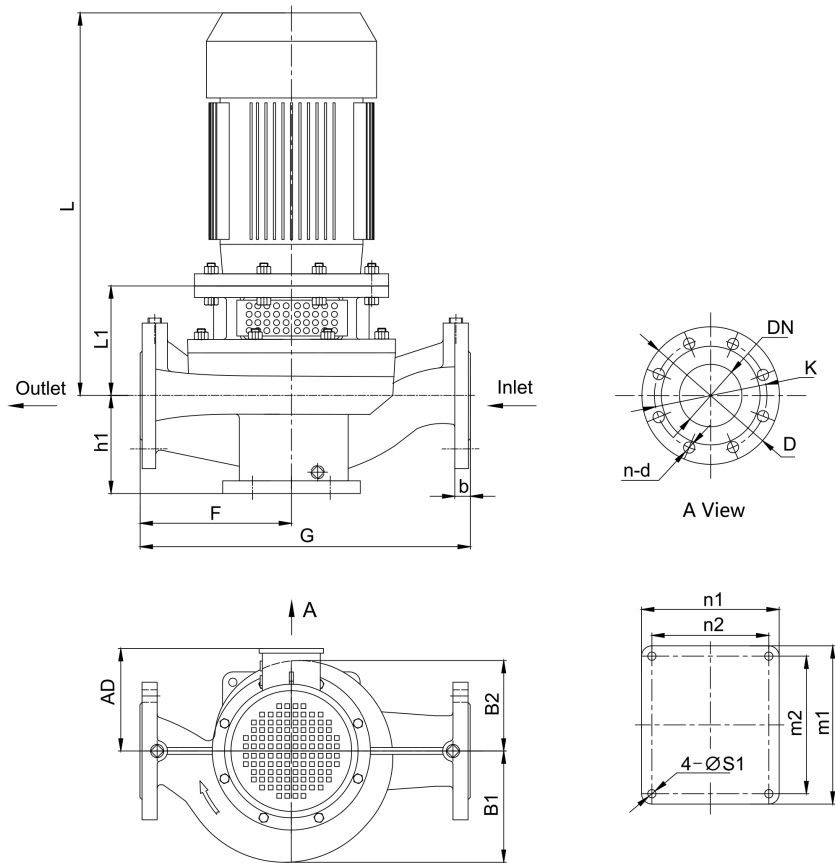

Pump Installation Size (inch)															
h1	L1	F	G	L	AD	B1	B2	n2 x m2	n1 x m1	S1	DN	D	K	n - d	b
7.4	8	11.4	23.6	24.9	8.3	7.6	6.5	6.7x7.9	7.9x9.1	0.6	4	9.1	7.5	8 - φ0.8	-

Project	Project ID	Created by	Created on	Last update
---------	------------	------------	------------	-------------



Performance Curves

Vertical In-line Pump - EGM100-8020-07504

Revision no. _____

Page:
 2

Receiver	From

Company name
 Respons. Department
 Person in charge
 Phone number
 Fax no
 E-mail address

Model	Capacity			Head		Speed	Motor	Voltage	Phase	Impeller Diam.		Eff.	(NPSH)r
	m ³ /h	l/s	gpm	m	ft	r/min	hp	v		mm	inch	%	ft
EGM100-8020-07504	73.4	20.4	323.3	18	59	1710	10	230/460	3	202	8	75	8.9
	122.4	34	538.9	15.7	52		10					83.5	12.5
	146.9	40.8	646.7	13	43		10					75	15.7

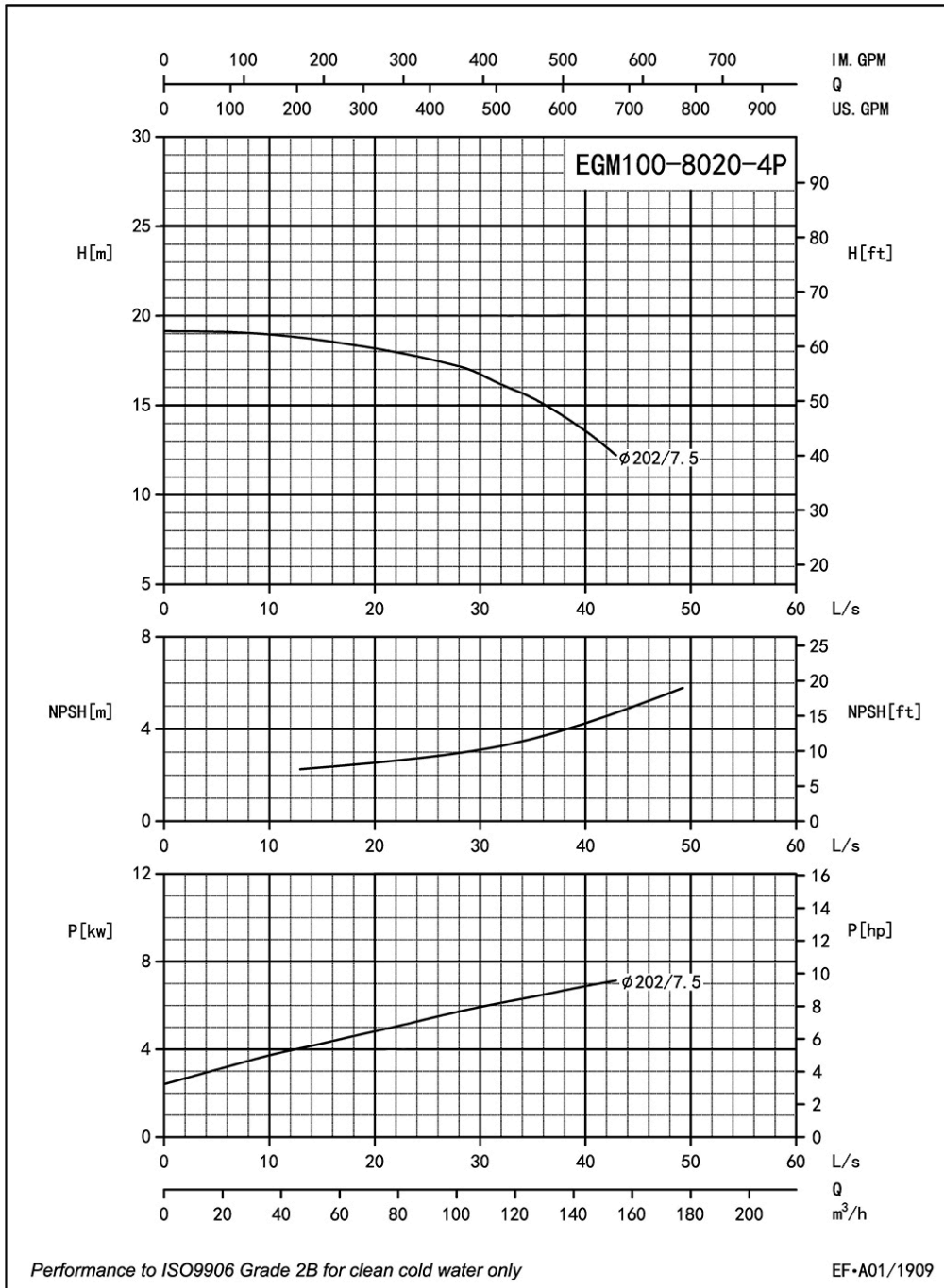

Project	Project ID	Created by	Created on	Last update
---------	------------	------------	------------	-------------



Parts List

Vertical In-line Pump - EGM100-8020-07504

Revision no.

Page:
 3

	Receiver	From
Company name		
Respons. Department		
Person in charge		
Phone number		
Fax no		
E-mail address		

Parts List

1 Casing	14 Screw
2 Impeller Nut	15 Screw Bolt
3 Flat Washer	16 Screw Nut
4 Spring Washer	17 Screw Bolt
5 Front-Wear Ring	18 1/4 Plug
6 Impeller	19 3/8 Plug
7 Seal Seat	20 Key
8 Mech Seal	21 Screw Nut
9 Casing Gasket	22 Motor
10 Casing Cover	23 Key
11 1/4 Plug	24 Screw
12 Adapter	25 Shaft
13 Guard	

Project	Project ID	Created by	Created on	Last update